



KTU CONSTRUCTORS

**SPECIAL PROVISIONS AND
SUPPLEMENTAL SPECIFICATIONS**

TO

**KTU CONSTRUCTORS' MARCH 2010
STANDARD SPECIFICATIONS FOR
CONSTRUCTION**

Effective March 23, 2011

TABLE OF CONTENTS

| | |
|---|-----------|
| SPECIAL PROVISIONS | 1 |
| SPECIAL PROVISION #1 - DEFINITIONS | 1 |
| SPECIAL PROVISION #2 - ASPHALTIC CONCRETE PAVEMENT | 1 |
| SPECIAL PROVISION #3 - BARRIER CURB DELINEATORS | 1 |
| SPECIAL PROVISION #4 - FOUNDATION INSPECTION FOR DRILLED SHAFTS | 2 |
| SPECIAL PROVISION #5 - LOAD BEARING PILES | 2 |
| SPECIAL PROVISION #6 - CONSTRUCTION SURVEYING ACTIVITIES | 3 |
| SPECIAL PROVISION #7 - DYNAMIC PILE TESTING | 10 |
| SPECIAL PROVISION #8 - SEEDING, MULCHING AND FERTILIZER | 13 |
| SPECIAL PROVISION #9 - ADDITIONAL APPLICABLE STANDARDS | 14 |
| <i>AAS 2.1 - PRESTRESSED CONCRETE CORED SLABS.....</i> | <i>15</i> |
| <i>AAS 2.2 - PRESTRESSED CONCRETE BOX BEAMS.....</i> | <i>17</i> |
| <i>AAS 2.3 - TESTING CONCRETE STRENGTH USING MATURITY METHOD.....</i> | <i>19</i> |
| <i>AAS 2.4 - REMOVAL OF FORMS AND FALSEWORK.....</i> | <i>21</i> |
| <i>AAS 2.13 - LOAD BEARING PILES.....</i> | <i>22</i> |
| <i>AAS 2.16 - EVAZOTE JOINT.....</i> | <i>23</i> |
| <i>AAS 2.17 - WATERPROOFING MEMBRANE.....</i> | <i>26</i> |
| <i>AAS 2.18 - CONCRETE PLACEMENT TEMPERATURE.....</i> | <i>30</i> |
| | |
| REVISIONS TO MARCH 2010 KTU CONSTRUCTORS STANDARD SPECIFICATIONS FOR CONSTRUCTION..... | 31 |
| SECTION 102 - BIDDING REQUIREMENTS AND CONDITIONS..... | 31 |
| SECTION 201 – CLEARING AND GRUBBING | 31 |
| SECTION 202 - REMOVAL OF ROADWAYS AND BUILDING..... | 31 |
| SECTION 216 - REMOVALS FOR BRIDGE STRUCTURES | 31 |
| SECTION 403 - ASPHALTIC CONCRETE PAVEMENT | 32 |
| SECTION 611 - EMBANKMENT PROTECTION | 32 |
| SECTION 616 - TEMPORARY TRAFFIC CONTROL | 32 |
| SECTION 617 - CONCRETE TRAFFIC BARRIER | 33 |
| SECTION 620 - PAVEMENT MARKING..... | 34 |
| SECTION 627 - CONTRACTOR SURVEYING AND STAKING | 34 |
| SECTION 701 - DRILLED SHAFTS | 34 |
| SECTION 702 - LOAD BEARING PILES | 34 |
| SECTION 704 - CONCRETE MASONRY REPAIR..... | 35 |
| SECTION 711 - PROTECTIVE COATINGS | 35 |
| SECTION 903 - HIGHWAY SIGNING..... | 36 |

SPECIAL PROVISIONS

SPECIAL PROVISION #1 - DEFINITIONS

For the purposes of the KTU Constructors Standard Specifications for Construction the following definitions shall apply:

Commission. The Missouri Highways and Transportation Commission.

Contractor. For the purposes of Standard Specifications and Special Provisions the term “contractor” shall be replaced with “subcontractor”.

Engineer. KTU Constructors or its Designer.

SPECIAL PROVISION #2 - ASPHALTIC CONCRETE PAVEMENT

All work associated with asphalt paving on and adjacent to the bridge decks with a commercial mix will be performed in accordance with this Special Provision as shown on the plans or as directed by the engineer. Any other asphalt paving will be performed in accordance with the Standard Specifications.

If the contractor chooses to use the concrete pavement option in lieu of asphalt as described on Sheet R-6 of the Drawings, joints shall be in accordance with MoDOT Standard Drawings 502.05M, Concrete Pavement and Base Appurtenances for 15' Joint Spacing.

STANDARD PAY ITEM: Section 401 – Asphaltic Concrete Pavement

The neat line quantity of asphalt paving included in the referenced pay item has been calculated to the nearest 0.1 tons by the engineer from the paving limits shown on the approved plans using a factor of 110 pounds per square yard – inch (sy-in). The minimum thickness of asphalt paving required on the bridge deck shall be two inches unless otherwise shown on the plans. The depth of asphalt over the surface of the bridge shall vary depending on the cross slope requirements and actual beam cambers. These variations shall be considered as included in the pay item plan quantity. Material, construction requirements, and acceptance criteria will be in accordance with the Standard Specifications.

The plan quantity of asphalt paving will be paid for at the Contract unit price for Section 401, Asphaltic Concrete Pavement. This payment will be considered full compensation for all work associated with the plan quantity of asphalt paving performed under this Section, including any mobilization and demobilization costs.

ALTERNATE PAY ITEM: Section 401 – Asphaltic Concrete Pavement (Overrun of Plan Quantity)

Any asphalt paving directed by the engineer or required by approved change order in excess of the plan quantity will be measured in the field to the nearest 0.1 tons by the engineer using a factor of 110 pounds per square yard – inch (sy-in). Material, construction requirements and acceptance criteria will be in accordance with the Standard Specifications.

If this work is directed by the engineer, it will be performed concurrently with the bridge overlay. No additional mobilization or demobilization will be required.

Asphalt paving in excess of the plan quantity, which has been directed and approved by the engineer, will be paid for at the alternate unit price for Asphaltic Concrete Pavement (Overrun of Plan Quantity). As an example, any asphalt paving placed by the contractor in excess of the plan quantity to adjust final bridge tie-in elevations or improve ride-ability that has been directed and approved by the engineer will be paid for under Asphaltic Concrete Pavement (Overrun of Plan Quantity). No additional measurement or payment will be made under this item for camber or cross-slope adjustments or replacement of asphalt surfacing damaged by the contractor.

This payment will be considered full compensation for all work associated with asphalt paving in excess of the plan quantity performed under this Section. No other added asphalt paving will be measured or paid for under this item unless the engineer expressly approves payment prior to performance of the additional work.

SPECIAL PROVISION #3 - BARRIER CURB DELINEATORS

Barrier curb delineators shall be placed on top of the barrier curb as shown on Missouri Standard Plans 617.10 and in accordance with Section 617 of the Standard Specifications. Delineators on bridges with two-lane traffic shall have retroreflective sheeting

on both sides.

Barrier curb delineators will be considered incidental to the barrier curb concrete.

SPECIAL PROVISION #4 - FOUNDATION INSPECTION FOR DRILLED SHAFTS

Where required under Section 701, foundation inspection (NX cores) for drilled shafts will be performed by the engineer (KTU) prior to the start of work. Television and other inspection will remain the responsibility of the contractor (Subcontractor) as indicated in the specifications.

SPECIAL PROVISION #5 - LOAD BEARING PILES

Where required under Section 702, pile splices will only be allowed and paid for where pile lengths exceed 60 feet or as directed by the engineer to minimize pile waste.

Contractor will fill any open-ended pipe pile with concrete to at least 2 feet below the scour elevation indicated in the geotechnical reports. If it is necessary to auger out the pile to achieve the required concrete depth, that and any related work will be considered incidental to Section 702, Load Bearing Piles (Pipe Pile).

Contractor will use the following detail when welding splices on steel pipe pile. Backing rings for splices on steel pipe pile will be furnished by KTU.

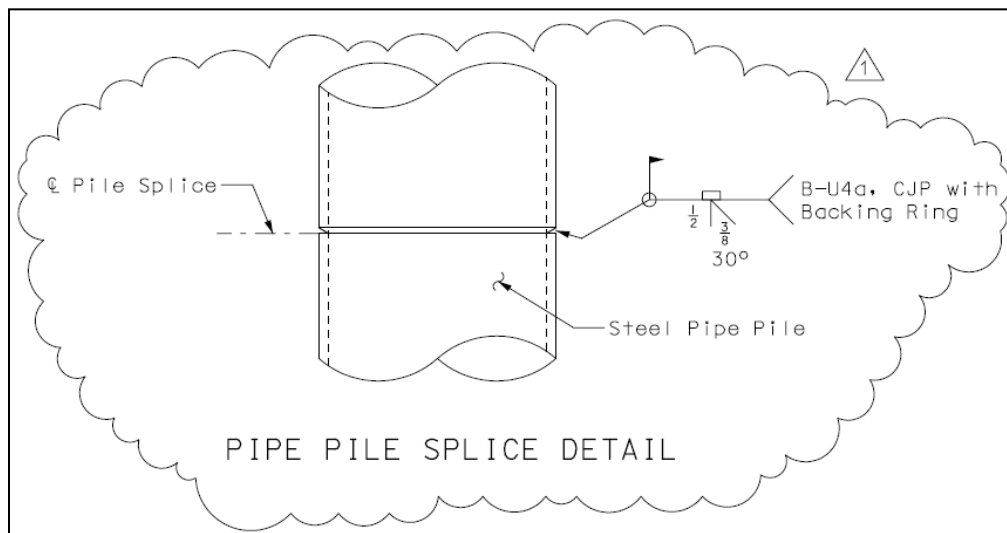

End plate welding will typically be conducted by the pipe pile supplier prior to delivery on-site. If contractor is required to weld end plates on steel pipe pile in the field, contractor will use the following detail.

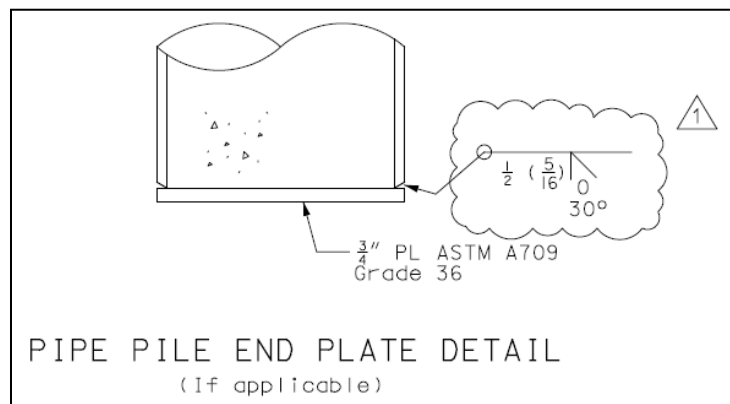

SPECIAL PROVISION #6 - CONSTRUCTION SURVEYING ACTIVITIES

1.0 General Instructions.

The contractor’s surveyor is expected to perform the staking required by the contract. The engineer will furnish the contractor’s surveyor with additional working points and benchmarks prior to the beginning of construction. The contractor’s surveyor should make working points available to the engineer upon request.

The engineer may check staking of bridges during construction. The contractor is responsible for final line and grade of the end product. The contractor’s surveyor should provide enough information and staking upon request so the engineer can adequately check the staking on the project. The contractor should maintain adequate working points during and after construction.

2.0 Datum and Units.

All coordinates shall be based on the State Plane Coordinate System, North American Datum (NAD) of 1983 (1997) in the appropriate Zone with zone grid to ground conversion. The elevations shall be based on the North American Vertical Datum (NAVD) of 1988. A minimum of two (2) benchmarks shall be established on each site and shall be designated on drawing with the label of TBM.

Linear measures will be made in the English System. The base unit will be the United States Survey Foot.

3.0 Tolerances.

The required degree of accuracy for conventional surveys is shown in the following table. The survey party is responsible for obtaining at least this degree of accuracy, through the proper adjustment and care of instruments and equipment and the method of making measurements.

| Survey Accuracy | |
|------------------------|----------------------------------|
| Measurement | Allowable Error |
| Distance | 1:20,000 |
| Angular | 6 Seconds |
| Levels | 0.05 ft. x Sq. Root Dist.(miles) |

4.0 Recording Accuracy.

Single measurements are recorded to the accuracy shown in the following table.

| Survey Recording Accuracy | |
|----------------------------------|------------------------------------|
| Measurement | Accuracy |
| Distance | 0.01 ft. |
| Angular | 5 Seconds |
| Levels | 0.01 ft. Bench Levels, Turns, etc. |
| | 0.01 ft. on Concrete |
| | 0.1ft. All Others |

5.0 Contractor Schedule.

Prior to bridge construction, survey layout notes and an as-staked electronic point file for the same shall be submitted for approval by the engineer, in a format similar to that provided below.

6.0 Pre-Construction Activities.

A minimum of and three (3) control points of suitable quality for new construction will be provided by the Engineer at each project bridge at locations indicated on the plans. Prior to the start of work the contractor’s surveyor shall verify survey vertical and horizontal control as well as pavement tie-ins noted in the construction documents for sufficiency and accuracy.

The contractor’s surveyor shall provide notes and electronic point files indicating checks to control and pavement tie-in points at the time of pre-construction meeting. In the event that discrepancies in control or pavement tie-out points are found the Engineer’s surveyor shall be contacted immediately for resolution).

7.0 Traffic Safety.

Survey parties are to utilize procedures that provide the maximum level of safety for their personnel and the traveling public. When working on the road, appropriate signage is used as a minimum guide for traffic safety. When working on the outside shoulder one "Survey Crew" sign is placed on that shoulder, preceding the work by 200 ft. in urban areas and 500 ft. in rural areas. When working in the median, "Survey Crew" signs are used facing both directions. When working outside the outside shoulder line signing is not normally used. The major factors bearing on the protection to be used in each situation are Speed, Volume of Traffic, Highway Geometrics, Duration of Operation, Exposure to Hazards and Weather (or road conditions).

Warning signs are placed at appropriate minimum distances. Field conditions will control the actual placement of signs and cones. The individual in charge of the survey party has the responsibility to see that the necessary safety precautions are taken. Proper personal protection equipment (PPE) is to be worn by all members of the survey party while working on the road, the shoulder or in the median. Where signs are used they are to be placed prior to beginning work and at locations having adequate approach visibility. Traffic cones (28 in. in height) are to be used as needed. Personnel using stop-slow paddles are positioned as needed to provide the best direction of traffic and safety for working personnel. Personnel must be instructed concerning the importance of staying alert, being courteous to motorists, and the fact that the responsibility for the lives of the party and traveling public are in their hands. The department publication "Safety Rules and Regulations" gives additional traffic control information. Trucks with top mounted flashers may be used to provide additional protection for personnel by blocking the lane or parking on the shoulder. Two-way radios may be used to handle traffic where two-way operation over a single lane is maintained without visible contact between personnel.

8.0 Survey Party Organization.

The construction staking party has two main functions:

1. Re-establish sufficient horizontal and vertical control points to assure convenient and accurate staking during construction.
2. Provide the contractor with enough stakes to indicate proper grade and alignment so the project can be constructed according to the plans.

Regardless of the makeup of the survey party, all construction surveying activities within MoDOT right of way must be performed under the supervision of a professional land surveyor (PLS) or a professional engineer (PE).

9.0 Equipment.

Available equipment must be checked to be sure it is in good condition, in proper calibration and adjusted for current weather conditions.

10.0 Contractor Staking.

The contractor will preserve all right of way monuments, benchmarks control points and reference marks set in the field. If any monuments are damaged, destroyed or disturbed by the contractor, the cost of replacement will be at the contractor's expense and will be deducted from payment for the work.

All surveying by the contractor will be documented in a written form acceptable to the engineer. During performance of the work, all surveying documents must be available and supplied to the engineer upon request, at the contractor's expense. All documents will be labeled with the route, state job number, county, contractor's name, survey party supervisor and date.

The engineer will furnish and set control points with known coordinates. The engineer will furnish all coordinate data to layout the job and locate benchmarks as shown on the plans. The contractor will provide all other staking necessary for the successful completion of the work. All alignment control established by the contractor must be referenced, and a copy furnished to the engineer.

All surveying work performed by the contractor must be sufficient and accurate to construct the work in accordance with the contract documents. Adjustments necessary to provide accurate staking or match improvements to existing features shall be immediately brought to the attention of the engineer. The engineer will determine the nature of the discrepancy and make revisions to the plans as necessary. The contractor shall perform any re-staking required by such revisions.

Centerline elevations will be based on the plan datum. All benchmarks shown on the plans will be checked. In the event a difference of plus or minus 0.01 ft exists in elevation for any benchmark shown on the plans, check levels must be run and shown in the notes. The elevations will be corrected to plan elevation at each benchmark where any difference occurs, and will be noted

in the field notes. If a plan benchmark has been disturbed or if correction of the plan elevation is not feasible, a full explanation must be made in the notes. The contractor will furnish to the engineer a listing of benchmarks prior to beginning construction.

Upon completion of the project, the contractor will provide the engineer all original surveying field notes, layouts and computations in standard bound survey notebooks or in an acceptable form.

11.0 Field Notebooks.

It is essential the contractor's personnel understand the staking methods to be used and the information that is shown on the stakes. This written record can ensure the contractor's work is successfully completed.

Where field notes are recorded directly in a surveying computer using the proper accounting for each of the various surveying tasks involved with construction surveys, the correct coding must always be used. Additional information (i.e., lists and descriptions of control points and chains, bench marks, etc.) is placed in standard field notebooks. Field notes shall include subject, project, job number, bridge number, county, date, crew members, equipment used and serial numbers, temperature and weather conditions.

Legibly record notes so others may readily interpret the information. When it is necessary to revise or delete any information entered in the field book, the entry is crossed through, initialed, and an explanation for the revision or deletion is made unless the reason is apparent. Good complete notes are valuable project records. Written field notes shall be column in format for all staking performed. Data shall include station, offset distance, staking feature description and cut/fill to finish grade and stored electronic point number (where electronic data collection is used). Electronically stored descriptions shall match those noted in the written field notes.

12.0 Quality Assurance.

Quality assurance checks by the engineer or the Commission do not relieve the contractor of their responsibility to construct the project to the specified lines and grades. The engineer's checks are to identify any contractor staking errors to minimize any adverse impacts to the project. They are also to help spot any plan errors. The contractor must be willing to assist in any checks. It is in both parties interest to catch any errors early on in the construction process. The contractor will place any additional stakes necessary for the engineer to properly check their surveying.

The contractor shall at a minimum stake and reference those centerlines and layout lines used as dimensional references on the plans. These lines include the following:

1. Bridge centerlines or layout lines.
2. Centerline of bents and piers, or fill face of abutments.
3. Centerline of footings.
4. Layout lines for wingwalls or retaining walls.

The following accuracy guidelines can be used:

1. Each stake on a bridge will be checked. The check must be within 0.01 ft. for both vertical and horizontal. Surveyors and inspectors will note that the end bents are staked at the fill face and not the centerline of the end bent.
2. Each wall stake will be checked. The tolerance is within 0.04 ft. both horizontal and vertical.
3. The entire cross section is checked every 50 ft. The tolerance for slope stakes is within 0.2 ft.
4. All paving grades are set to finish grade. Checks are made not only at the individual stake but also at the next stake forward and backward. It is recommended a document record be produced with a diagram of the way the pavement is staked. This assures both parties are in concurrence. Grading and paving contractor's often like things staked differently. Hub line tolerances are horizontal 0.10 ft. and vertical 0.04 ft.
5. Specific structure element locations such as piles, edge of footing, end of wall or other details that can be located from staked lines and plan dimensions are optional staking items. These are established by the contractor and checked by the engineer.

6. Station numbers shown on the plans are the stations at the ends of bridge, usually at the fill face of the end bents. At least 2 substantial tacked hubs are set well past each end of the bridge, preferably on high ground that will not be disturbed during construction. This gives 4 points on centerline of bridge. If one is lost or destroyed, the line may still be recreated. From the station at the end of the bridge, location of the first bent or abutment can be determined. The work line for end bents is generally the fill face. At least 2-tacked hubs are set on each side of the bridge clear of all construction activities, for each pier, bent, or abutment and on each side of a footing.
7. Clearing limits and environmental protection barriers: Shall be according to construction documents at the discretion of the contractor. The clearing limits are generally marked 10 ft. beyond the planned slope line to allow for grading and the adjustment of slope-stakes to fit original ground.

13.0 Land and U.S. Survey Monuments.

It is important to preserve all land monuments of section corners, subdivision corners and all U. S. Government monuments within the right of way. It is the engineer's policy to cooperate in their preservation. An examination of plans is made for the location of section lines or subdivision lines crossing or intersecting other such lines within the right of way.

The contractor shall preserve all survey control monuments and any governmental defined land corners that are located on Right of Way. The contractor shall notify the engineer as soon as it becomes known that a monument is in a position that will interfere with new construction or with contractor operations. The monument position shall be accurately preserved prior to disturbing any such monument.

If an existing marker is disturbed, or cannot be preserved in place, the contractor's PLS shall set the new marker in accordance with the requirements of 20 CSR 2030-16. The contractor shall furnish and install new survey monuments in accordance with the standards for permanent monuments, including a cap stamped with MHTC's name, and the highway station and offset for that location as detailed in the EPG.

14.0 U.S.G.S. Monuments.

A U.S. Geological Survey monument may serve as both a level monument and a traverse monument. If it becomes necessary to move one of these monuments, immediately notify:

United States Geological Survey, MCMC
1400 Independence Road, MS-800
Rolla, Missouri 65401
Telephone No.: 573-341-0940

In the notification, give a general description of the area in which the monument is located, together with the designation stamped on the bronze plate. The U.S.G.S. will either send a party to move it, or send forms on which to enter the description of the new location and field notes for revision of data. If project forces move a level monument, the difference in elevation only need be recorded with proper field notes to substantiate the difference. To preserve accuracy as nearly as possible, the difference in elevation is given to the one-thousandth of a foot. For a traverse monument, the determined data is true bearing to the nearest 1/2 degree, with horizontal distance to the nearest one-tenth foot from old to new location. Where true bearing is not available, reference the monument with some accurate transit ties so exact location can be re-established. Send this information to U.S.G.S. so they can reset the monument with their own forces.

15.0 MoDOT CORS Real Time Network (RTN).

In the event that horizontal and vertical control monuments cannot be located or ascertained from an inspection of salient features the surveyor may use the MoDOT RTN to find or establish necessary site control. MoDOT Real Time Network is made up of a series of GNSS (Global Navigation Satellite System) receivers strategically located to cover the entire state at a maximum distance of 70 km, collecting data 24 hours a day. The network uses US GPS and Russian Glonass signals and is expandable to future signals such as Galileo.

All stations have been built to NGS (National Geodetic Survey) CORS (Continuously Operating Reference System) specifications. All sites will be submitted to NGS for incorporation into the national system. Data is sent to a central server through an Internet connection for processing. Users can obtain this data in two ways:

1. Real Time which allows them to get instant corrections as they work.
2. From our web site (gpsweb.modot.mo.gov) which allows them to download files to their computer for Post Processing.

The objective of the system is to provide real time kinematic (RTK) data via the Internet for use in improving GPS data collection accuracy. MoDOT has made access of this system available to users in the area without cost after MoDOT ensured that its needs and the needs of its other governmental partners have been met. Users of the MoDOT system must obtain a username and password, have a bluetooth cell phone capable of tethering or a data modem in their surveying equipment and a high speed, unlimited data plan through their cellular provider which has the best coverage in their area (ATT, Verizon etc.).

Cell service coverage is the key to effective use of the network however, if cellular coverage cannot be obtained in a particular area, the network has a website available for downloading data collected at the time of the field collection. This method allows a user to post process his survey results and obtain the desired level of accuracy without being connected to the network in the field. Uses of an RTK GPS network might include: Surveying, GIS data collection, Construction, Machine Control, Automatic Vehicle Location, Asset Management, Automated road salting, Snowplow guidance, unmanned mowers. Some of the benefits of using a Reference Station Network system of this type include the elimination the need for local base stations and the personnel required to “watch” the local base station, enforcement of a consistent known datum, and use of a known coordinate system. As with any survey GPS solution, a localization file should be created for each project to orient the project coordinates to the network coordinates (state plane). This needs to be done only once and is used throughout the life of the project. For more information on the MoDOT GPS RTK network, access the network web site at <http://gpsweb.modot.mo.gov> .

16.0 Field Notes Legend.

| | |
|---------|----------------------|
| Instr. | Instrument |
| HI | Height of Instrument |
| BS | Backsight |
| HR | Height of Rod |
| Delta H | Horizontal Error |
| Delta V | Vertical Error |
| STA | Station |
| Elev | Elevation |
| C/F | Cut or Fill |
| Desc | Description |

BRIDGE: B0148 TASK: STAKE WEST BENT
 DATE: 02/10/11 FILE NAME: B0148.DC

CREW: J. SURVEY
 B. MONEY

WIND: 0-5 MPH
 WEATHER: SUNNY
 TEMP: 40F

| | | | |
|--|----------------|----------|-------------------|
| INSTR. @ | CP2 | HI: | 5.68 |
| 1002 | BS: CP1 | HR: | 6.00 |
| | $\Delta H:$ | 0.014 | $\Delta V:$ 0.012 |
| 1003 | CHECK: PT# 503 | HR: | 6.00 |
| | $\Delta H:$ | 0.021 | $\Delta V:$ 0.013 |
| STAKED 10 AND 20 FOOT OFFSETS TO CENTERLINE OF WEST BENT, GRADED TO TOP OF BENT, STORE POINTS 1004-1008. | | | |
| CUTSHEET | | | |
| POINT # OR STA | DESIGN ELEV | HUB ELEV | C/F/DESC |
| 1004 | 10' 982.45 | 976.23 | F6.22 TOP BENT |
| 1005 | 20' 982.45 | 975.11 | F7.34 TOP BENT |
| 1006 | 10' 982.45 | 977.65 | F4.80 TOP BENT |
| 1007 | 20' 982.45 | 977.22 | F5.23 TOP BENT |
| 1008 | CHECK: CP3 | HR: | 6.00 |
| | $\Delta H:$ | 0.016 | $\Delta V:$ 0.008 |

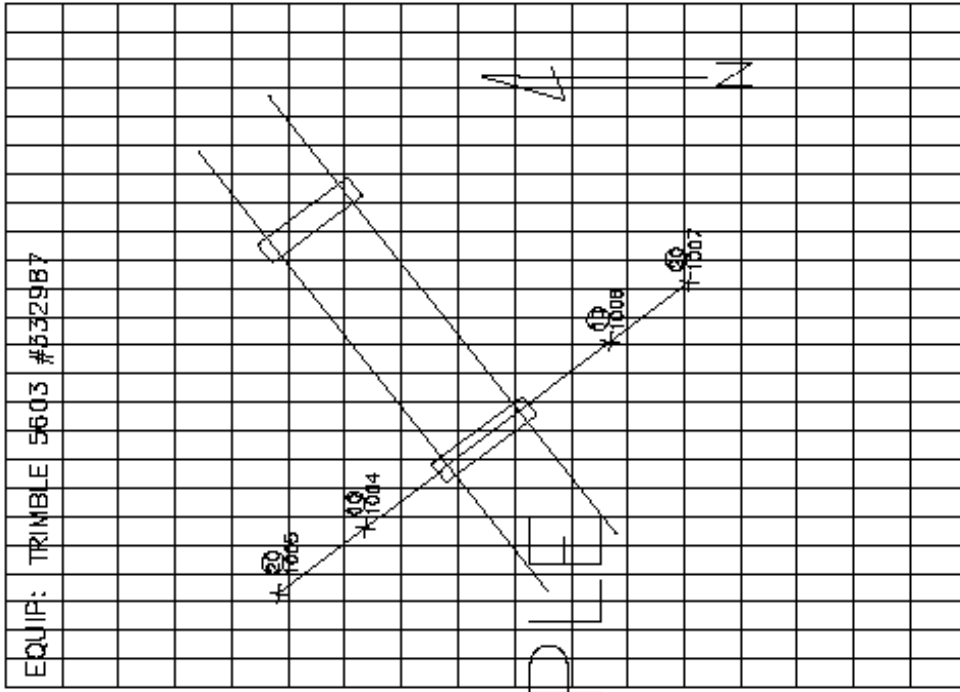

SAMPLE

| | | | | | | |
|--|---------------------------------|--|-----------------------------|----------|-----|------|
| BRIDGE: _____ DATE: _____ | TASK: _____ FILE NAME: _____ | WIND: _____ WEATHER: _____ TEMP: _____ | CREW: _____ EQUIP: _____ | | | |
| INSTR. | HI: _____ | SKETCH & NOTES | | | | |
| BS: _____ | HR: _____ | | | | | |
| ΔH: _____ | ΔV: _____ | | | | | |
| CHECK: _____ | HR: _____ | | | | | |
| ΔH: _____ | ΔV: _____ | | | | | |
| SHORT DESCRIPTION OF WHAT WAS STAKED, OFFSET DISTANCES, POINT RANGE FROM THIS SETUP | | | | | | |
| CUTSHEET | | | | | | |
| POINT # OR STA | DESIGN ELEV | | | HUB ELEV | C/F | DESC |
| CONTINUE FORMAT FOR ADDITIONAL SETUPS, AND INCLUDE A CHECK SHOT TO ANOTHER KNOWN POINT AT THE END OF EACH SETUP. | | | | | | |
| DELIVERABLES TO KTU SURVEY MANAGER BY EMAIL: | | | | | | |
| 1) PDF OF FIELD NOTES | | | | | | |
| 2) POINT FILE (PNEZD) IN CSV FORMAT | | | | | | |

SAMPLE

SPECIAL PROVISION #7 - DYNAMIC PILE TESTING

1.0 General.

1.1 Scope of Work. Scope of work shall include furnishing all labor, equipment and analysis associated with dynamic testing of driven piles as specified in this special provision.

1.2 Performance and Design Requirements. Performance and design conditions for dynamic testing of driven piles shall be in accordance with Section 4.0 of this special provision.

1.3 Approved Manufacturers. For the following hardware and software components, only the listed manufacturer is recognized as providing the level of quality required. If the contractor wants to propose a non-listed manufacturer that is considered to provide an equivalent level of quality, this manufacturer shall be identified and supporting documentation provided. Acceptance of the manufacturer as a substitute will be at the discretion of KTU.

| Component | Product | Manufacturer |
|--|-----------------------------------|---------------------|
| Pile Driving Modeling - Wave Equation Software | GRLWEAP | Pile Dynamics, Inc. |
| Pile Driving Monitoring - Hardware & Software | Pile Driving Analyzer - Model PAK | Pile Dynamics, Inc. |
| Pile Driving Analysis – Signal Matching Software | CAPWAP | Pile Dynamics, Inc. |

1.4 Test Requirements. Dynamic pile testing shall be conducted in accordance with the standard test method indicated below.

| Standard Test Method | Designation | Conducted By |
|--------------------------------------|--------------------|---------------------|
| High-Strain Dynamic Testing of Piles | ASTM D 4945 | Contractor |

1.5 Qualifications. The contractor shall perform dynamic pile testing utilizing the services of an independent dynamic pile testing consultant and qualified personnel. Personnel with professional engineering licensure (P.E.) with a minimum of 3 years dynamic pile testing and analysis experience or who has achieved Basic or better certification under the High-Strain Dynamic Pile Testing Examination and Certification process of the Pile Driving Contractors Association and Foundation QA shall perform pile driving monitoring. Personnel with a P.E. and a minimum of 5 years dynamic pile testing and analysis experience or who has achieved Advanced or better certification under the High-Strain Dynamic Pile Testing Examination and Certification process of the Pile Driving Contractors Association and Foundation QA shall perform pile driving modeling and pile driving analyses.

2.0 Execution.

2.1 Pile Driving Modeling. The contractor shall perform preconstruction wave equation analyses and prepare a summary report of the results. The wave equation analyses shall be used to assess the ability of all proposed pile driving systems to install piles to the required capacity and the desired penetration depth within allowable driving stresses. The report shall include a drivability graph relating pile capacity, blow count and driving stresses to depth. The report shall include a bearing graph relating the pile capacity to the pile driving resistance. The bearing graph shall indicate blow count versus capacity and stroke. The report shall also contain a constant capacity analysis or inspectors chart to assist the contractor in determining the required driving resistance at other field observed strokes. The contractor shall perform wave equation analyses in accordance with Section 4.0 of this special provision. Acceptability of the wave equation report and the adequacy of analyses will be determined by KTU.

2.1.1 Approval by KTU of the proposed pile driving system will be based upon the wave equation analyses indicating that the proposed system can develop the specified pile capacity at a pile driving rate of 2 to 10 blows per inch at the end of driving, and within allowable driving stresses per *AASHTO LRFD Bridge Construction Specifications*, Section 4.4.1. The contractor shall provide preliminary pile driving criteria based on wave equation analyses and any anticipated capacity changes after driving, set-up or relaxation, subject to revision based upon dynamic pile testing field measurements.

2.1.2 If any changes or modifications are made to the approved pile driving system, additional wave equation analyses in accordance with Section 2.1 of this special provision shall be required.

2.2 High-Strain Dynamic Pile Testing.

2.2.1 The contractor shall perform dynamic pile testing (PDA) at the locations and frequency required in accordance with Section 4.0 of this special provision and approved by KTU.

2.2.2 Dynamic pile testing involves monitoring the response of a pile subjected to heavy impact applied by the pile hammer at the pile head. The testing shall provide information on the driving stresses, pile capacity, structural integrity and hammer efficiency.

2.2.3 The contractor shall engage an independent dynamic pile testing consultant and qualified personnel in accordance with Section 1.5 of this special provision. Prior to testing, KTU will review and approve the proposed independent dynamic pile testing consultant, the experience and qualifications of assigned personnel, details of the method of testing, a list of equipment, and the method of analysis of test results. The contractor shall provide all available details of the subsurface conditions, pile dimensions and properties, and pile driving systems to the independent dynamic pile testing consultant.

2.2.4 All field testing and measurements shall be made in the presence of KTU.

2.3 Field Testing.

2.3.1 Equipment. Dynamic pile testing field measurements shall be carried out using approved equipment, software and recording equipment. The data collected at the end of initial driving shall be analyzed using approved signal matching techniques and software.

2.3.2 Monitoring During Driving. During pile driving, piles shall be instrumented and monitored with testing equipment satisfying the requirements of Section 1.3 of this special provision. Re-strike of PDA tested pile may be required prior to demobilizing the crane from site as directed by KTU if unusual circumstances occur.

2.3.2.1 The contractor shall install two sets of strain transducers and accelerometers near the top of each pile to be tested, and shall use a compatible measuring and recording system to record the data during driving.

2.3.2.2 The hammer and all site equipment used shall be capable of delivering an impact force sufficient to mobilize the specified pile capacity indicated in Section 4.0 of this special provision without damaging the pile.

2.3.2.3 The testing equipment shall monitor pile stresses during driving to prevent pile damage and ensure pile integrity and capacity. If the testing equipment indicates overstressing or damage to the pile, the contractor shall immediately discontinue driving and notify KTU.

2.3.2.4 If the testing equipment determines that pile stresses during driving exceed acceptable levels, a new pile driving system, modifications to existing system or new pile installation procedures shall be proposed by the contractor. Approval by KTU of any proposed changes to the pile driving system or pile installation procedures will be based upon the results of additional wave equation analyses in accordance with Section 2.1.2 of this special provision.

2.3.3 Preparation of the Pile Head. The preparation of the pile head should conform to ASTM D 4945 for the application of dynamic test load. It shall involve, where appropriate, trimming the head, cleaning, and building up the pile using materials that shall, at the time of testing, safely withstand the impact stresses. The impact surface shall be flat and at right angles to the pile axis.

2.3.4 Dynamic Measurement and Analysis. Monitoring of pile driving shall begin when pile driving begins. The data shall be recorded and processed immediately in the field by the pile driving monitoring equipment and software. Unless monitoring indicates that additional driving will damage the pile, pile driving and monitoring shall continue until the specified pile capacity is reached, and the minimum tip elevation (if specified) is obtained. For each pile tested, pile driving analysis (PDA) using signal matching techniques shall be performed for a selected blow at the end of driving to determine the relative capacities from end bearing and skin friction along the pile.

2.3.4.1 KTU may request use of pile driving monitoring equipment and software on additional piles if inconclusive results are obtained or unusual driving conditions are encountered.

2.3.4.2 Pile bearing capacity and integrity shall be evaluated based on the standard procedure used in practice.

2.3.4.3 Tabular records of the dynamic pile testing field measurements obtained at the end of initial driving shall be immediately provided to KTU by the contractor.

2.3.4.4 Prior to demobilizing from site, dynamic pile testing agency shall provide driving criteria to contractor and range of pile capacities based on assumed soil damping factors.

2.3.5 Results.

2.3.5.1 Summary Reports. The contractor shall prepare a summary report for each pile tested for review by KTU. Each report shall contain tabular as well as graphical presentation of the dynamic test results versus depth. The report shall include the results of hammer performance, pile driving stresses, and pile capacity during initial driving for all piles tested. In addition to the above information, each report shall also indicate the pile driving criteria for the additional piles to be installed at the substructure unit

or bridge of the pile tested. Each summary report shall include the following:

- (a) Date of testing and date of pile installation.
- (b) Bridge number, pile identification number, and location.
- (c) Length of pile below commencing surface.
- (d) Total length of pile, including projection above commencing surface at time of test.
- (e) Length of pile from instrumentation position to tip.
- (f) The maximum force applied to the pile head.
- (g) The maximum pile head velocity.
- (h) The maximum energy imparted to the pile.
- (i) Static capacity estimate.
- (j) Blows per inch at end of initial driving.
- (k) Stroke.
- (l) Hammer type, drop, and other relevant details.
- (m) Blow selected for signal matching analysis.
- (n) Maximum compressive and tensile stresses, stroke, and capacity versus penetration depth.
- (o) Temporary compression.
- (p) Pile integrity and location of damage, if any.
- (q) Force/velocity versus time trace.
- (r) Force/velocity match curve.
- (s) Resistance distribution along the pile.
- (t) Detailed graphical and tabular results from blow analyzed using signal matching techniques and software.

3.0 Schedule of Contract Submittals.

| Item Number | Submittal Item | Type | Calendar Days | Event/Date |
|-------------|--|------|---------------|----------------------------------|
| 1 | Proposed independent dynamic pile testing consultant, and a listing of assigned personnel and their experience and qualifications. | DOCS | 21 Before | Start of Pile Driving Monitoring |
| 2 | Details of the components, method of testing, pile driving equipment and materials to be used, and the results of wave equations analyses. | DOCS | 14 Before | Start of Pile Driving Monitoring |
| 3 | Four copies of each Summary Report as defined in section 2.3.5.1 of this special provision | DOCS | 3 After | Completion of Each Field Test |

4.0 High-Strain Dynamic Pile Testing Specification.

| Item | Requirement |
|-------------------------------|--|
| Wave Equation Analysis | Minimum of 1 per bridge structure and sufficient additional analyses as needed to define performance for all combinations of piles, driving systems and subsurface conditions anticipated. |
| Dynamic Testing Pile Capacity | Nominal Axial Pile Compressive Resistance, or 2.5 times the Design Bearing shown on the plans, or as required by KTU |

| Item | Requirement |
|--|--|
| High-Strain Pile Dynamic Testing | Minimum of 1 per bridge structure as noted on plans, or as required by KTU |
| Pile Driving Analyses using Signal Matching Techniques | For each High-Strain Pile Dynamic Test |

5.0 Method of Measurement. Dynamic pile testing will be measured per each individual High-Strain Pile Dynamic Test and will include pile driving monitoring and pile driving analysis performed. If re-strikes are required by the engineer, they shall be considered a separate test.

6.0 Basis of Payment. Payment for the above described work, including all material, equipment, tools, labor and any other incidental work necessary to complete this item, will be considered completely covered by the contract unit price for "Dynamic Pile Testing".

SPECIAL PROVISION #8 - SEEDING, MULCHING AND FERTILIZER

1.0 The contractor shall seed, mulch, and fertilize all areas disturbed during construction operations in accordance with the pertinent sections of Division 800 or as directed by the engineer.

2.0 The contractor shall submit for approval seeding and fertilizing mixtures and rates appropriate for the local conditions. Absent an alternative approved mix, the contractor shall use the seeding and fertilizing mixtures and rates shown below for all disturbed areas.

2.1 Seeding. In accordance with Section 805 of the Standard Specifications, the following seed mixtures shall be applied at the rate specified:

| Seeding Mixture | Lbs / Acre | |
|------------------------|----------------------|-----------------------|
| | Warm Season | Cool Season |
| Tall fescue | | 80 lbs |
| Indiangrass | 8 lbs | |
| Big bluestem | 4 lbs | |
| Little bluestem | 6 lbs | |
| Sideoats grama | 4 lbs | |
| Switchgrass | 2 lbs | |
| Virginia or Canada rye | 2 lbs | |
| Tall dropseed | 0.5 lbs | |
| Purple prairie clover | 0.5 lbs | |
| Annual ryegrass | 10 lbs | 10 lbs |
| Perennial ryegrass | 5 lbs | 5 lbs |
| Red fescue | 10 lbs | |
| Redtop | 0.5 lbs | |
| Partridge pea | 2 lbs | |
| White Clover | 5 lbs | 5 lbs |
| Grayheaded Coneflower | 0.25 lbs | |
| Black-eyed Susan | 0.25 lbs | |
| Oats | 20 lbs | 10 lbs |
| TOTAL | 80 lbs / acre | 110 lbs / acre |

2.2 Fertilizing. The following fertilizing agent shall be applied at the rate specified:

| Fertilizer | Lbs/Acre | |
|---------------------------------|-------------|-------------|
| | Cool Season | Warm Season |
| Nitrogen (N) | 40 | 40 |
| Phosphoric Acid (P205) | 40 | 40 |
| Soluble Potash (K20) | 40 | 40 |
| Effective Neutralizing Material | 500 | 500 |

2.0 Basis of Payment. All work associated with seeding, mulching or fertilizing will be paid for under Section 805, Seeding.

SPECIAL PROVISION #9 - ADDITIONAL APPLICABLE STANDARDS

The following Additional Applicable Standards (AAS) that were submitted with KTU's Final Technical Proposal and approved by the Commission are included with the Special Provision and supplement or replace the Standard Specifications as described therein:

- (a) AAS 2.1 - Prestressed concrete cored slabs
- (b) AAS 2.2 - Prestressed concrete box beams
- (c) AAS 2.3 - Testing concrete strength using maturity method
- (d) AAS 2.4 - Removal of forms and falsework
- (e) AAS 2.13 - Load bearing piles
- (f) AAS 2.16 - Evazote joint
- (g) AAS 2.17 - Waterproofing membrane
- (h) AAS 2.18 - Concrete placement temperature

AAS 2.1
PRESTRESSED CONCRETE CORED SLABS

2.1.1 General. Prestressed concrete cored slab units similar to those in use by the North Carolina DOT will be used on the project as appropriate according to the following. This specification was developed from the following documents, available in KTU's Final Technical Proposal:

- (a) Sample drawings showing details of the adjacent and spread cored slabs.
- (b) NCDOT specifications 430 and 1078 for cored slabs.
- (c) NCDOT Structure Design Manual Section 6-4 discussing cored slab use.

2.1.1.1 Transverse Connection of Units. Bridges will be joined together transversely with post tensioning strand or post-tensioning bars located at the interior diaphragms as shown on the Released for Construction drawings.

2.1.1.2 Skew. Girders shall be fabricated and erected on the skews shown in the Released for Construction drawings.

2.1.1.3 Allowable Stresses. Allowable stresses will be in accordance with the AASHTO Standard Specifications for Highway Bridges, 17th Edition.

2.1.2 Fabrication. Place concrete in accordance with Section 1029 and the additional requirements of this article. Place concrete for cored slabs in 2 or more horizontal layers. Place and compact each layer before the preceding layer takes initial set so that there is no surface or separation between layers. Should shrinkage or settlement cracks occur, the engineer reserves the right to require additional layers and/or vibration. These requirements may be waived with the permission of the engineer if self consolidating concrete is used.

When cored slabs are cast, a positive hold-down system shall be employed to prevent voids from moving. Design the system to be left in place until the concrete has reached the release strength. At least six weeks prior to casting cored slabs, the manufacturer shall submit to the engineer for review and comment, detailed drawings of the proposed void material and hold-down system. In addition to structural details, location and spacing of the hold-downs shall be indicated. The manufacturer shall also submit his proposed method of concrete placement and of consolidating the concrete under the void.

2.1.2.1 Finish. This special provision replaces 1029.6.14 and 1029.6.15 in its entirety. The top surface of the cored slab sections shall be as shown on the Released for Construction drawings..

Surface finish shall be in accordance with Sec 703.3.5.8, except that no cracks of any kind in post-tensioned members shall be filled before the stressing is completed. The engineer will determine the kind, type and extent of cracks and surface defects, such as honeycomb and chipped edges or corners, that will be tolerated. Repairs may be permitted with mortar in accordance with Sec 703.3.2.9. Commercially available patching material may be used if approved by the engineer.

For cored slabs that will carry a concrete deck or overlay, the top surface of members shall be scored transversely to a depth of approximately 1/4 inch (6 mm) with a wire brush, stiff broom or other approved method. A 3-inch (75 mm) wide strip across the top flange of the member shall be smooth finished to accurate top flange depth at each point designated on the plans. No laitance shall remain on surfaces to be embedded in concrete.

For cored slabs that will carry a waterproofing membrane and asphalt overlay, the top surface of members shall be broom finished with a stiff broom or other approved method. A 3-inch (75 mm) wide strip across the top flange of the member shall be smooth finished to accurate top flange depth at each point designated on the plans. No laitance shall remain on surfaces.

After removal of hold-down devices, holes shall be plugged. If the method for plugging these holes is not shown on the shop drawings, written approval of the proposed method shall be obtained from the engineer. Exposed reinforcing steel shall be thoroughly cleaned of all concrete before delivery of members. The portions of girders to be embedded in the diaphragms at supports shall be roughened by sandblasting or other approved methods to provide suitable bond between girder and diaphragm. Mechanical benders, without the use of heat, shall be used to bend the strands on girders.

No surface finish is required for sides and bottom of the cored slab sections except the exposed side of the exterior beam section as noted on the plans. Provide a resulting surface finish essentially the same color and surface finish as the surrounding concrete.

2.1.2.2 Alignment and Dimensional Tolerances. Ensure that pieces fit together neatly and in a workmanlike manner. Manufacture cored slabs within the tolerances indicated in Section 1029.7, Table I.

2.1.3 Erection. Erect Cored Slabs in accordance with Section 705.4.2 and the additional requirements of this article. Post-tensioning of cored slabs shall be in accordance with 1029.6.9. After erecting prestressed cored slabs, place the transverse post tensioning strands and tension to the jacking force specified on the plans. The transverse strands shall be greased and placed in a noncorrosive 1/16" minimum wall thickness black polyethylene pipe meeting the requirements of ASTM D2239. Do not apply grease or extend the pipe in the area of the recesses at the ends of the tensioning strands where grout is applied. If tie rods are specified on the plans, tighten the tie rods to the torque specified on the plans. After stressing the transverse post tensioning strands or tightening tie rods, fill the shear key, dowel holes, and recesses at the ends of transverse strands with an approved non-metallic, non-shrink grout and cure until the grout reaches a minimum compressive strength of 3000 psi.

After tensioning and curing, obtain approval prior to placing material and equipment on the cored slab spans. Place support cranes or other equipment exceeding the legal load limit on mats. Submit for review a detailed drawing for the mats that are intended for use on the cored slabs. Provide a complete description of the equipment that is intended for placement on the mats. Supply and construct mats at no additional cost to the engineer.

2.2.4 Payment. Payment for cored slabs shall be made in accordance with Section 705.

AAS 2.2
PRESTRESSED CONCRETE BOX BEAMS

2.2.1 General. Prestressed concrete box beam units similar to those in use by the North Carolina DOT will be used on the project as appropriate according to the following. This specification was developed from the following documents, available in KTU's Final Technical Proposal:

- (a) Sample drawings showing details of the adjacent and spread box beams.
- (b) Original NCDOT specifications 430 and 1078 for box beams.
- (c) Original NCDOT Structure Design Manual Section 6-4 discussing box beam use.

2.2.1.1 Transverse Connection of Units. Bridges will be joined together transversely with post-tensioning strand or post-tensioning bars located at the interior diaphragms as shown on the Released for Construction drawings. Bridges with concrete overlay will be joined together with a combination of the composite overlay and 1" diameter Grade A36 tie rods. Transverse connection of box beam units will only be required for bridges with adjacent box beam units.

2.2.1.2 Skew: Girders shall be fabricated and erected on the skews shown in the Released for Construction drawings..

2.2.1.3 Allowable Stresses. Allowable stresses will be in accordance with the AASHTO Standard Specifications for Highway Bridges, 17th Edition.

2.2.2 Fabrication. Place concrete for box beams in 2 or more horizontal layers. Place and compact each layer before the preceding layer takes initial set so that there is no surface or separation between layers. Should shrinkage or settlement cracks occur, the engineer reserves the right to require additional layers and/or vibration. These requirements may be waived with the permission of the engineer if self consolidating concrete is used.

When box beams are cast, a positive hold-down system shall be employed to prevent voids from moving. Design the system to be left in place until the concrete has reached the release strength. At least six weeks prior to casting box beams, the manufacturer shall submit to the engineer for review and comment, detailed drawings of the proposed void material and hold-down system. In addition to structural details, location and spacing of the hold-downs shall be indicated. The manufacturer shall also submit his proposed method of concrete placement and of consolidating the concrete under the void.

2.2.2.1 Finish. This special provision replaces 1029.6.14 and 1029.6.15 in its entirety. The top surface of the box beam sections shall be as shown on the Released for Construction drawings.

Surface finish shall be in accordance with Sec 703.3.5.8, except that no cracks of any kind in post-tensioned members shall be filled before the stressing is completed. The engineer will determine the kind, type and extent of cracks and surface defects, such as honeycomb and chipped edges or corners, that will be tolerated. Repairs may be permitted with mortar in accordance with Sec 703.3.2.9. Commercially available patching material may be used if approved by the engineer.

For box beams that will carry a concrete deck or overlay, the top surface of members shall be scored transversely to a depth of approximately 1/4 inch (6 mm) with a wire brush, stiff broom or other approved method. A 3-inch (75 mm) wide strip across the top flange of the member shall be smooth finished to accurate top flange depth at each point designated on the plans. No laitance shall remain on surfaces to be embedded in concrete.

For box beams that will carry a waterproofing membrane and asphalt overlay, the top surface of members shall be broom finished with a stiff broom or other approved method. A 3-inch (75 mm) wide strip across the top flange of the member shall be smooth finished to accurate top flange depth at each point designated on the plans. No laitance shall remain on surfaces.

After removal of hold-down devices, holes shall be plugged. If the method for plugging these holes is not shown on the shop drawings, written approval of the proposed method shall be obtained from the engineer. Exposed reinforcing steel shall be thoroughly cleaned of all concrete before delivery of members. The portions of girders to be embedded in the diaphragms at supports shall be roughened by sandblasting or other approved methods to provide suitable bond between girder and diaphragm. Mechanical benders, without the use of heat, shall be used to bend the strands on girders.

No surface finish is required for sides and bottom of the box beam sections except the exposed side of the exterior beam section as noted on the plans. Provide a resulting surface finish essentially the same color and surface finish as the surrounding concrete.

2.2.2.2 Alignment and Dimensional Tolerances. Ensure that pieces fit together neatly and in a workmanlike manner.

Manufacture box beams within the tolerances indicated in Section 1029.7, Table I.

2.2.3 Erection. Erect Box Beams in accordance with Section 705.4.2 and the additional requirements of this article. Post-tensioning of box beams shall be in accordance with 1029.6.9. After erecting prestressed box beams, place the transverse post tensioning strands and tension to the jacking force specified on the plans. The transverse strands shall be greased and placed in a noncorrosive 1/16" minimum wall thickness black polyethylene pipe meeting the requirements of ASTM D2239. Do not apply grease or extend the pipe in the area of the recesses at the ends of the tensioning strands where grout is applied. If tie rods are specified on the plans, tighten the tie rods to the torque specified on the plans. After stressing the transverse post tensioning strands or tightening tie rods, fill the shear key, dowel holes, and recesses at the ends of transverse strands with an approved non-metallic, non-shrink grout and cure until the grout reaches a minimum compressive strength of 3000 psi.

After tensioning and curing, obtain approval prior to placing material and equipment on the box beam spans. Place support cranes or other equipment exceeding the legal load limit on mats. Submit for review a detailed drawing for the mats that are intended for use on the box beams. Provide a complete description of the equipment that is intended for placement on the mats. Supply and construct mats at no additional cost to the engineer.

2.2.4 Payment. Payment for Box Beams shall be made in accordance with Section 705.

AAS 2.3
TESTING CONCRETE STRENGTH USING MATURITY METHOD

2.3.1 Description. When approved in writing by the engineer, this maturity method, similar that in use by the Iowa DOT, may be used on the project as appropriate according to the following. This specification was developed from Iowa DOT Material IM 383, available in KTU's Final Technical Proposal:

2.3.2 General. Measuring the strength of Portland Cement Concrete using the Maturity Method is a two-step procedure. First, a relationship must be established between the maturity values and the concrete strength as measured by destructive methods (that is, through testing of beams or cylinders). The development of the maturity-strength curve shall be done in the field at the beginning of construction using project materials and the project proportioning and mixing equipment. The second step is the instrumentation of the concrete to be measured. Temperature probes are installed in the concrete and the temperature is measured. From those measurements, along with the age at which the measurements were taken, maturity values are determined. A maturity meter of temperature-measuring device and a computer or calculator may also be used to determine the maturity values.

2.3.2.1 The contractor shall develop a plan for performing the maturity testing. The plan shall include:

- (a) The contractor shall be responsible for the development of the maturity curve. The curve development shall be monitored by the engineer.
- (b) The temperature monitoring process of the constructed pavement or structure shall be the responsibility of the contractor and shall be monitored by the engineer. Determining that sufficient strength has been achieved shall remain the responsibility of the engineer. The contractor shall provide documentation of maturity testing before a pavement section may be opened to traffic, a structure may be loaded, or the forms may be removed.

2.3.2.2 For concrete furnished from a construction or stationary mixer, which is in place prior to construction of the specified project, a maturity curve may be established ahead of actual construction of the specified project. The test specimens shall be cast with concrete made from the same plant and using the same materials source as will be used in the specific project. The engineer shall be informed and have an opportunity to observe the development of the maturity curve.

2.3.3 Implementation. For pavements, when used at the contractor's option with the approval of the engineer, it is the intent of the procedure to use the maturity method to open the pavement to traffic from the very first day of paving, including the days of development of new curves. Pavement

2.3.3.1 Placed on the first day during development of the strength-maturity curve may be opened when either of the following criteria has been met:

- (a) The TTF of the slab, or structure, meets or exceed the opening TTF as determined by the strength-maturity curve being developed.
- (b) At a particular test age, the average strength of the three beams used for development of the strength-maturity curve meets or exceeds the required opening strength.

2.3.3.2 For structures, since maturity is to be used on units exposed to flexural loading, the maturity curve should be developed early in the project during placement of concrete exposed to compressive stress. If this is not possible, concrete placed on the same day as development of the strength-maturity curve may be loaded at a particular age using either of the first day placement criteria required for pavements.

2.3.4 Validation. Once per month, or as directed by the engineer, validation tests shall be conducted to determine if concrete strength is being represented by the current maturity curve. Cast and cure three (3) beams using the same procedure and manner as used to develop the current maturity curve. Test all three beams as close as possible to the maturity value determined to represent the opening strength of the pavement or the flexural loading strength or form removal strength of the structure.

2.3.4.1 For pavements, if the average calculated strength value at the TTF the validation beams were tested is within the range of ± 50 psi (0.34 MPa) of the original curve, the original curve shall be considered validated. If the average calculated strength at the TTF the validation beams were tested is lower than the minimum range (-50 psi (-0.34 MPa)) of the original maturity curve, a new maturity curve shall be developed. If the average calculated strength at the TTF the validation beams were tested is greater than the maximum range (+50 psi (+0.34 MPa)) of the original maturity curve, a new maturity curve may be developed at the contractor's option with the approval of the engineer.

2.3.4.2 For structures, if the average calculated strength is greater than the original curve at the TTF the validation beams were tested, the original curve shall be considered validated. If the average calculated strength is less than the original maturity curve

at the TTF the validation beams were tested, a new maturity curve shall be developed.

2.3.5 Factors Requiring a New Curve. Changes in material sources, proportions, and mixing equipment all affect the maturity value of a given concrete mixture. Development of a new maturity curve due to material source or proportion changes in a concrete mix may be waived by use of the validation procedure. The following will require a new curve to be developed:

- (a) The average calculated strength at the TTF the validation beams were tested is lower than the minimum range (-50 psi (-0.34 MPa)) of the original maturity curve (pavements only).
- (b) The w/c ratio of the production concrete exceeds the w/c ratio of the concrete used to develop the strength maturity curve by more than 0.02.

AAS 2.4
REMOVAL OF FORMS AND FALSEWORK

2.4.1 Description. When approved in writing by the engineer, this method for the removal of forms and falsework, similar that in use by the Texas DOT, may be used on the project as appropriate according to the following. This specification was developed from Texas DOT 410S, available in KTU's Final Technical Proposal:

2.4.2 General. Unless otherwise indicated on the drawing, forms for vertical surfaces may be removed when the concrete has aged 12 hours after initial set, provided it can be done without damage to the concrete. Forms for mass concrete placements shall be maintained in place for 4-days following concrete placement. Mass placements are defined as concrete placements with a least dimension greater than equal to 5 ft. (1.575 meters), or those designated as such on the drawings.

2.4.2.1 Forms for inside curb faces may be removed in approximately 3 hours provided it can be done without damage to the curb. Unless indicated otherwise on the drawings weight supporting forms and falsework spanning more than 1 ft. (300 mm) for structures, bridge components and culvert slabs shall remain in place until the concrete has attained a minimum compressive strength of 2500 psi (17.25 MPa). Forms for other structural components may be removed as approved by the engineer.

2.4.2.2 Inside forms (walls and top slabs) for inlets, box culverts and sewers may be removed after the concrete has attained a minimum compressive strength of 1800 psi (12.4 MPa), provided an overhead support system, approved by the engineer, is used to transfer the weight (mass) of the top slab to the walls of the box culvert or sewer before the support provided by the forms is removed.

2.4.2.3 If all test cylinders made for the purpose of form removal have been broken without attaining the required strength, forms shall remain in place for a total of 14 curing days.

2.4.2.4 The above provisions relative to form removal shall apply only to forms or parts thereof which are constructed to permit removal without disturbing forms or falsework required to be left in place for a longer period on other portions of the structure.

2.4.2.5 Remove all metal appliances used inside forms for alignment shall be removed to a depth of at least ½ in. (13 mm) from the concrete surface. The appliances shall be manufactured to allow the removal without undue chipping or spalling of the concrete, and so that it leaves a smooth opening in the concrete surface when removed. Rods, bolts and ties shall not be burned-off.

2.4.2.6 All forms and falsework shall be removed unless indicated otherwise on the drawings.

AAS 2.13
LOAD BEARING PILES

2.13.1 Description. With the approval of the engineer, modified hammer energies, similar those in use by the Iowa DOT, will be used for driving piles when larger energies are considered appropriate at a particular site. Larger hammer energies are permitted by the Iowa DOT's current standard specifications. Steel H-piles will be considered for use as either end bearing piles or friction piles. This specification was developed from the following documents, available in KTU's Final Technical Proposal:

- (a) Proposed special provision for the use of larger hammer energies and for the use of H-piles as friction piles.
- (b) Original Iowa DOT specification section 2501 for piling.

2.13.2 Hammer Energies. Section 702.3.5 of the Standard Specifications will be modified as follows:

2.13.2.1 Maximum hammer energies of 60,000 foot-pounds (for steel piles) and 40,000 foot-pounds (for concrete piles) will be used for pile installation. The increased maximum hammer energies do not relieve the contractor of the responsibility to provide equipment suitable for driving the specified pile(s) to the required bearing value and /or pile tip elevation without inducing unacceptable stresses and/or damage to the pile(s).

2.13.2.2 Structural steel piles (H-piles) will be considered for use as either friction piles or bearing piles. When used as friction piles, the practical refusal criteria of a pile bearing value equal to 1.9 times the design bearing value (as stipulated in Sec. 702.4.11 of the *Missouri Standard Specifications*) will not be applicable.

**AAS 2.16
EVAZOTE JOINT**

SECTION 2.16.10 DESCRIPTION AND CLARIFICATIONS

2.16.10.1 Description. As directed by the engineer and indicated on the plans, Evazote Joint Seals, similar those in use by the North Carolina DOT will be used as an expansion seal for bridges requiring an expansion joint device. The NCDOT Evazote joint specification included below is approved for use on this project with the following exceptions:

- (a) Range of allowable movement is between 0 and 4 inches.
- (b) No limit on maximum skew.
- (c) Maximum compression in seal is 60% of the nominal seal width.
- (d) Maximum tension in seal is 30% of the nominal seal width.
- (e) Maximum shearing movement 120% of the nominal seal width.
- (f) Armoring of Evazote expansion joints is not required.
- (g) The use of an “elastomeric concrete filled” blockout is not required. The seal will be attached directly to the sides of the formed opening.

SECTION 2.16.20 NCDOT EVAZOTE JOINT SEALS SPECIFICATION (8-13-04)

1.0 Seals.

Use preformed seals compatible with concrete and resistant to abrasion, oxidation, oils, gasoline, salt and other materials that are spilled on or applied to the surface. Use a low-density closed cell, cross-linked ethylene vinyl acetate polyethylene copolymer nitrogen blown material for the seal.

Use seals manufactured with grooves 1/8" (3 mm) ± wide by 1/8" (3 mm) ± deep and spaced between 1/4 (6 mm) and 1/2 inch (13 mm) apart along the bond surface running the length of the joint. Use seals sized so that the depth of the seal meets the manufacturer’s recommendation, but is not less than 70% of the uncompressed width. Provide a seal designed so that, when compressed, the center portion of the top does not extend upward above the original height of the seal by more than 1/4 inch (6 mm). Splice the seal using the heat welding method by placing the joint material ends against a Teflon heating iron of 350°F (177°C) for 7 - 10 seconds, then pressing the ends together tightly. Do not test the welding until the material has completely cooled. Use material that resists weathering and ultraviolet rays. Provide a seal that has a working range of 30% tension and 60% compression and is watertight along its entire length including the ends.

Provide seals that meet the requirements given below.

| TEST | TEST METHOD | REQUIREMENT |
|---|--|---|
| Elongation at break | ASTM D3575 | 210 ± 15% |
| Tensile strength, psi (kPa) | ASTM D3575 | 110 ± 15 (755 ± 100) |
| Compression Recovery (% of original width) | AASHTO T42 50% compr. for 22 hr. @ 73°F (23°C) 1/2 hr. recovery | 87 ± 3 |
| Weather/Deterioration | AASHTO T42 Accelerated Weathering | No deterioration for 10 years min. |
| Compression/Deflection | @ 50% deflection of original width @ 50% deflection of original width | 10 psi (69 kPa) min. 60 psi (414 kPa) max. |
| Tear Strength, psi (kPa) | ASTM D624 | 16 ± 3 (110 ± 20) |
| Density | ASTM D545 | 2.8 to 3.4 |
| Water Absorption (% vol/vol) | ASTM D3575 Total immersion for 3 months | 3 |

Have the top of the evazote seal clearly shop marked. Inspect the evazote seals upon receipt to ensure that the marks are clearly visible upon installation.

2.0 Adhesives.

Use a two component, 100% solid, modified epoxy adhesive with the seal that meets the requirements of ASTM C881, Type 1, Grade 3, Class B & C and has the following physical properties:

| | |
|---------------------------|--------------------------|
| Tensile strength..... | 3500 psi (24.1 MPa) min. |
| Compressive strength..... | 7000 psi (48.3 MPa) min. |
| Shore D Hardness | 75 psi (0.5 MPa) min. |
| Water Absorption..... | 0.25% by weight |

Use an adhesive that is workable to 40°F (4°C). When installing in temperatures below 40°F (4°C) or for application on moist, difficult to dry concrete surfaces, use an adhesive specified by the manufacturer of the joint material.

3.0 Sawing The Joints.

When the plans call for sawing the joints, the joints shall be initially formed to a width as shown on the plans including the blackout for the elastomeric concrete. Complete placement of the elastomeric concrete after the reinforced concrete deck slab has cured for seven full days and reached a minimum strength of 3000 psi (20.7 Mpa).

Cure the elastomeric concrete for a minimum of 2 days prior to sawing the elastomeric concrete to the final width and depth as specified in the plans.

When sawing the joint to receive the evazote seal, always use a rigid guide to control the saw in the desired direction. To control the saw and to produce a straight line as indicated on the plans, anchor and positively connect a template or a track to the bridge deck. Do not saw the joint by visual means such as a chalk line. Fill the holes used for holding the template or track to the deck with an approved, flowable non-shrink, non-metallic grout.

Saw cut to the desired width and depth in one or two passes of the saw by placing and spacing two metal blades on the saw shaft to the desired width for compression seals.

The desired depth is the depth of the seal plus 1/4 inch (6 mm) above the top of the seal plus approximately 1 inch (25 mm) below the bottom of the seal. An irregular bottom of sawed joint is permitted as indicated on the plans. Grind exposed corners on saw cut edges to a 1/4" (6 mm) chamfer.

Remove any staining or deposited material resulting from sawing with a wet blade to the satisfaction of the engineer.

Use extreme care to saw the joint straight to the desired width and to prevent any chipping or damage to sawed edges of the joint.

4.0 Preparations For Sawed Joints.

When the plans call for sawing the joint, the engineer thoroughly inspects the sawed joint opening for spalls, popouts, cracks, etc. Make all necessary repairs prior to blast cleaning and installing the seal.

Immediately before sealing, clean the joints by sandblasting with clean dry sand. Sandblast to provide a firm, clean joint surface free of curing compound, loose material and any foreign matter. Sandblast without causing pitting or uneven surfaces. The aggregate in the elastomeric concrete may be exposed after sandblasting.

After blasting, either brush the surface with clean brushes made of hair, bristle or fiber, blow the surface with compressed air, or vacuum the surface until all traces of blast products and abrasives are removed from the surface, pockets, and corners.

If nozzle blasting, use compressed air that does not contain detrimental amounts of water or oil.

Examine the blast cleaned surface and remove any traces of oil, grease or smudge deposited in the cleaning operations.

Bond the seal to the blast cleaned surface on the same day the surface is blast cleaned.

5.0 Preparations For Armored Joints

When the plans call for armored joints, form the joint and blackout openings in accordance with the plans. If preferred, wrap the

temporary form with polyethylene sheets to allow for easier removal. Do not use form release agents.

- (a) **Submittals.** Submitting detailed working drawings is not required; however, submitting catalog cuts of the proposed material is required. In addition, direct the joint supplier to provide an angle segment placing plan.
- (b) **Surface Preparation.** Prepare the surface within the 48 hours prior to placing the elastomeric concrete. Do not place the elastomeric concrete until the surface preparation is completed and approved.
 - (1) Angle Assembly. Clean and free metalized steel of all foreign contaminants and blast the non-metalized steel surfaces to SSPC SP-10. Blast-cleaning anchor studs is not required.
 - (2) Concrete. Prior to placing the elastomeric concrete, thoroughly clean and dry all concrete surfaces. Sandblast the concrete surface in the breakout and clear the surface of all loose debris.
- (c) **Elastomeric Concrete Placement.** Make sure that a manufacturer's representative is present when placing elastomeric concrete. Do not place elastomeric concrete if the ambient air temperature is below 45°F (7°C). Prepare and apply a primer, as per manufacturer's recommendations, to all vertical concrete faces, all steel components to be in contact with elastomeric concrete, and to areas specified by the manufacturer. Align the angles with the joint opening. Prepare, batch, and place the elastomeric concrete in accordance with the manufacturer's instructions. Place the elastomeric concrete in the areas specified on the plans while the primer is still tacky and within 2 hours after applying the primer. Pay careful attention to properly consolidate the concrete around the steel and anchors. Trowel the elastomeric concrete to a smooth finish.
- (d) **Joint Preparation.** Prior to installing the seal, the engineer thoroughly inspects the armored joint opening for proper alignment and full consolidation of elastomeric concrete under the angle assemblies. Make all necessary repairs prior to cleaning the joint opening and installing the seal. Clean the armored joint opening with a pressure washer rated at 3000 psi (20.7 MPa) minimum at least 24 hours after placing the elastomeric concrete. Dry the cleaned surface prior to installing the seal. Examine the cleaned surface and remove traces of oil, grease or smudge deposited during the cleaning operations. Bond the seal to the cleaned surface on the same day the surface is cleaned.

6.0 Seal Installation.

Install the joint seal according to the manufacturer's procedures and recommendations and as recommended below. Do not install the joint seal if the ambient air temperature is below 45°F (7°C). Have a manufacturer's representative present during the installation of the first seal of the project.

Begin installation at the low end of the joint after applying the mixed epoxy to the sides of both the joint material and both sides of the joint, making certain to completely fill the grooves with epoxy. With gloved hands, compress the material and with the help of a blunt probe, push it down into the joint until it is recessed approximately 1/4 inch (6 mm) below the surface. Do not push the seal at an angle that would stretch the material. Once work on a joint begins, do not stop until it is completed. Clean the excess epoxy off the surface of the joint material *quickly and thoroughly*. Do not use solvents to remove excess epoxy. Remove excess epoxy in accordance with the joint manufacturer's recommendations.

Install the seal so that it is watertight. Testing of the joint seal is not required, but it is observed until final inspection.

7.0 Measurement and Payment. All work required and performed under this Section will be considered incidental to Section 703, Class B-2 Concrete (Superstructure).

AAS 2.17
WATERPROOFING MEMBRANE

SECTION 217.10 DESCRIPTION AND CLARIFICATIONS

2.16.10.1 Description. As directed by the engineer and indicated on the plans, waterproofing membrane for bridges, similar that in use by the Colorado DOT, will be used on this project. CDOT Standard Specifications 515, 705.07, 705.08 and 705.09 included below are approved for use on this project.

A Waterproofing Membrane will be applied to the top of precast cored slab and box beam structures when the route 2012 Average Daily Traffic volume is 1000 vehicles per day or less. An asphalt overlay will be placed on top of the waterproofing membrane.

SECTION 217.20 CDOT STANDARD SPECIFICATION SECTION 515 WATERPROOFING MEMBRANE

Description

515.01 This work consists of furnishing and placing an approved waterproofing membrane and protective covering over a prepared concrete bridge deck surface or furnishing and placing an approved chemical concrete sealer (sealer) on the surface of a concrete bridge deck, approach slabs, and all adjacent sidewalk and curb, and other applications designated on the plans.

Materials

515.02 The waterproofing membrane shall consist of one of the following:

- (1) A prefabricated reinforced membrane and primer or,
- (2) A single component, hot applied, elastomeric membrane and primer if required.

Materials for the waterproofing membrane shall meet the requirements specified in the following subsections:

- (1) Protective Covering 705.07
- (2) Prefabricated, Reinforced Membrane and Primer 705.08
- (3) Single Component, Hot Applied, Elastomeric Membrane 705.09

The following products are approved for use on this project:

- (1) Prefabricated Reinforced Membrane and Primer – Ohio DOT Type III Membrane Waterproofing
 - Primer Coat – 3405 as manufactured by W.R. Meadows
 - Type III Membrane – Ohio Type III waterproofing as manufactured by W.R. Meadows
- (2) Protective Covering – Tamko Master Smooth as manufactured by Tamko Building Products
- (3) Single Component, Hot Applied, Elastomeric Membrane Deery 102 as manufactured by Deery American Corporation

The following products will not be approved for use on this project (similar products from the manufacturer(s) listed below may also be rejected at the sole discretion of the engineer):

- (1) Polyguard NW-75 Membrane
- (2) Polyguard 650 RC

515.03 Concrete sealer shall consist of an alkyl-alkoxy silane and shall be a penetrating type with 40 percent solids in water or a high flash organic solvent. The sealer shall be compatible with the curing compound used on the concrete and shall be one that is included on the approved products list of the Department. A certificate of compliance shall be provided with each shipment of sealer.

Construction Requirements

515.04 Waterproofing Membrane.

(a) *Condition of Concrete Deck for Application of Waterproofing Membrane.* The entire deck and the sides of the curbs for a height of 2 inches above the plan thickness of the hot mix asphalt shall be free of all foreign material such as dirt, grease, old pavement and primer. All decks shall be prepared immediately prior to waterproofing. Preparation shall include removal of concrete protrusions, cleaning and sweeping. Removal of protrusions shall be by scraping, grinding or other methods approved

by the engineer. Cleaning shall include removal of laitance, oil, grease, or other foreign materials by either sand blasting or shot blasting. Sweeping shall include removing dirt, dust and moisture with brooms and compressed air. The deck condition will be approved before application of the membrane.

(b) *Weather and Moisture Limitations for Application of Waterproofing Membrane.* Application of primer or membrane shall not be done during inclement weather conditions, or when deck and ambient air temperatures are below 50 F. The deck surface shall be dry at the time of application of primer and membrane.

(c) *Application, Prefabricated, Reinforced Membrane.* Primer shall be applied to the prepared concrete surface at the rate and according to the procedure recommended by the membrane manufacturer. Placement of the membrane shall not begin until the volatile material in the primer has dissipated. The membrane shall be placed in such a manner that a shingling effect will be achieved and any accumulation of water will be directed toward curbs and drains. Primer and membrane shall be placed on the curb faces for a height of 2 inches above the plan thickness of the hot mix asphalt. The entire membrane shall be essentially free of wrinkles, air bubbles and other placement defects. Blisters or bubbles larger than 2 inches in diameter, which develop after placement of the membrane and before placement of protective covering, shall be punctured, the air expelled and membrane patched in a manner satisfactory to the Engineer. At all expansion joints, and other joints, membrane shall be flashed up to the top of the joint and secured with primer. At drain pipes, membrane shall be placed in such a manner that it extends down inside the drain and is secured with primer.

Special Instructions for Installation of Ohio Type III Membrane:

Keep membrane and primer materials dry before installation. Heat the membrane primer in an oil primer heated, double-jacket kettle. Use a kettle that is clean and free of other materials with any obvious buildup scraped out. The Contractor may use a single-jacket kettle if the primer is capable of being heated in direct fire to the application temperature. Heat primer within the manufacturer's recommended temperatures. Apply primer no further than 5 feet in front of the membrane using a squeegee to fill all voids and imperfections. Apply membrane from the low to the high side of the surface. Apply an extra bead of primer at the edge of the membrane. Lap joints in membranes by at least 3 inches. After installing the membrane over the entire surface, seal joints in the membrane by applying primer and smoothing with a V-squeegee.

(d) *Application, Single Component, Hot Applied, Elastomeric Membrane.* Hot applied membrane shall be applied to the prepared deck surface at a uniform minimum rate of ½ gallon per square yard thickness of 90 to 110 mils, 1 mil = 0.001 inch. During application the thickness may be measured by the Engineer. Lack of uniform application shall be cause for termination of the work until remedial measures are taken. Primer, if required, and membrane shall be placed up the curb faces for a height of 2 inches above the plan thickness of hot mix asphalt.

(e) *Application of Protective Covering.* As soon as practical, but in all cases the same day as membrane application, protective covering shall be placed from gutter line to gutter line. Protective covering shall be laid parallel to the centerline of the bridge. The protective covering shall be butted together at longitudinal and transverse joints. Overlapping will not be permitted. The maximum allowable space between adjoining sections of protective covering shall be 1 inch. Following placement of protective covering, a bead of compatible mastic or hot applied membrane shall be applied where the protective covering contacts the curbs, and in cracks between adjoining sections that are apart by more than 3/8 inch. The bead shall fill the void preventing water from entering at this point.

(f) *Inspection.* Upon completion of the membrane and protective covering the Engineer will inspect the membrane system. Approval in writing from the Engineer shall be obtained before application of hot mix asphalt. The Contractor shall be responsible for maintaining the condition of the membrane system on the bridge deck until covered with hot mix asphalt to the thickness required by the Contract.

(g) *Overlay.* Hot mix asphalt shall be placed, spread and compacted, in accordance with the specifications or as approved.

515.05 Concrete Sealer.

(a) *Condition of Surface for Application of Sealer.* The surface of bridge deck, approach slabs, sidewalks, and curbs and the interior concrete surface of drains shall be free of all residue and other surface contaminants. Within 48 hours prior to the application of the sealer these surfaces shall be cleaned with dustless abrasive shot blasting. Other methods of blasting, power washing, or cleaning may be used if approved. The amount of shot blasting or cleaning shall be sufficient to remove all visual evidence of curing compound residue, dirt, grease, and surface contaminants. When wet methods are used the surface shall be dried in accordance with subsection 515.04.

(b) *Weather and Moisture Limitations for Application of Sealer.* Sealer shall not be applied when the deck or ambient air temperature is below 40 F, above 90 F, or outside the manufacturer's recommended temperature range. The concrete shall have aged a minimum of 28 days and the surface shall be dry at the time of application of the sealer. When the surface is wet because of inclement weather, power washing, or other moisture it shall be permitted to dry at least 24 hours before the sealer is applied.

(c) *Application of Sealer.* Sealer shall be applied uniformly at a minimum rate of 1 gallon per 100 square feet of surface area. The sealer shall be applied to the surface of the concrete bridge deck, approach slabs, curbs including the face of concrete bridge rail for 6 inches above the bridge deck, sidewalks, and the interior concrete surface of drains. Two copies of the manufacturer's literature for the sealer including the recommended application procedure shall be provided to the Engineer prior to application. The literature shall include a product material safety data sheet. All solvents, coatings, or other chemical products, or solutions, shall be mixed, handled, applied, stored and disposed of in such a manner that spills, splashes, and drips shall be contained without contamination of the soil, vegetation, streams, or other water bodies. The Contractor shall provide two approved respirators for use by Department personnel. Traffic shall not be allowed on the treated surface until the sealer has penetrated the concrete and the liquid sealer is no longer visible on the surface. The Contractor shall follow all the manufacturer's recommendations, including penetration time, prior to opening to traffic.

Method of Measurement

515.06 No direct measurement for payment will be made for this item of work.

Basis of Payment

515.07 All work required and performed under this Section will be considered incidental to Section 711, Waterproofing Membrane.

SECTION 217.30 CDOT STANDARD SPECIFICATION SECTION 705.07 PROTECTIVE COVERINGS

705.07 Protective Covering for Bridge Deck Waterproofing Membrane. The protective covering shall be composed of one or more layers of felt thoroughly bonded together and saturated with asphalt. Both exposed sides shall be asphalt coated. The density shall be 55 pounds per 100 square feet. The surfaces shall be coated with suitable mineral matter to prevent the material from sticking to itself. The covering may be furnished either in rolls or sheets. The covering shall be free of visible external defects, such as holes, ragged or untrue edges, breaks, cracks, tears, protuberances, and indentations. The covering furnished in rolls shall not crack nor be so sticky as to cause material damage upon being unrolled at atmospheric temperatures as low as 50 °F. The covering shall conform to the following requirements when tested in accordance with Colorado Procedure L-2202:

| Property Determined | Specification |
|---------------------------------------|---|
| Width | Min. 35 ½", Max. 60 ½" |
| Pliability at 25 °C (77 °F) | At least 4 of 5 strips shall not crack when bent 90° over a rounded corner of 13 mm (½") radius. |
| Behavior on heating to 80 °C (176 °F) | Max. 1.5 percent volatile loss. No flowing, sagging or blistering. |
| Weight per square foot | 0.5 lbs |

Protective covering may be conditionally accepted in the field based on visual inspection for appearance, workmanship, and weight per square foot of a representative specimen.

SECTION 217.40 CDOT STANDARD SPECIFICATION SECTION 705.08 MEMBRANE AND PRIMER

705.08 Prefabricated, Reinforced Membrane and Primer. The membrane shall be a factory laminated sheet composed of either rubberized asphalt, bituminous mastic, or similar compounds reinforced with synthetic or fiberglass fabric. It shall be uniformly manufactured free from blemishes, discontinuities, and other defects. The membrane shall be supplied in rolls, having a minimum width of 30 inches and shall conform to the following requirements:

| Property Determined | Test Procedure | Specification |
|---------------------|----------------|-----------------|
| Thickness | | 70 mils minimum |
| Pliability | CP L-2203 | No cracks |

The primer used to bond membrane to the deck and to seal seams and patches shall be a water resistant adhesive compatible with the membrane. The primer shall be of suitable consistency for application by brush, roller, or spray without further dilution.

SECTION 217.50 CDOT STANDARD SPECIFICATION SECTION 705.09 ELASTOMERIC MEMBRANE

705.09 Single Component, Hot Applied, Elastomeric Membrane. The membrane shall be capable of being sprayed or spread to a uniform thickness at the application temperature recommended by the manufacturer. After cooling it shall form a tough resilient membrane, well bonded to the concrete surface and shall conform to the requirements of ASTM D 6690 Type 2, except that blocks for the bond test shall be as described in ASTM D 1985.

The membrane material shall be pretested by the Department prior to use. The batch or lot of the product will be placed on the Department's Approved Product List.

AAS 2.18
CONCRETE PLACEMENT TEMPERATURE

2.16.10.1 Description. Cast-in-place structural concrete placement will be performed using temperature limitations similar to those used by the Texas Department of Transportation. Concrete placement temperatures will be limited by the following criteria:

- (a) Maximum Cast-in-Place Placement Temperature: Drilled shaft foundations, substructure concrete and barriers will be placed at a temperature below 95 degrees.
- (b) Maximum Precast Concrete Placement Temperature: Precast concrete beams and barriers will be placed at a temperature below 95 degrees.
- (c) Maximum Bridge Deck Concrete Placement Temperature: Bridge deck concrete or concrete in the top slab of a direct-traffic culvert shall be placed at a temperature below 85 degrees.

The above temperature limitations have been developed from the following:

- (a) TxDOT Standard Specifications for Construction and Maintenance of Highways, Streets and Bridges, Section 420.4 discussing concrete placement temperatures. Particular attention is directed to section 420.4.G.1 which presents concrete placement temperature limitations.
- (b) TxDOT Standard Specifications for Construction and Maintenance of Highways, Streets and Bridges, Section 421.4.A, Table 5 which discusses the classes of structural concrete referenced in 420.4.G.1 discussing concrete placement temperatures.

REVISIONS TO MARCH 2010 KTU CONSTRUCTORS STANDARD
SPECIFICATIONS FOR CONSTRUCTION

SECTION 102 - BIDDING REQUIREMENTS AND CONDITIONS

Add the following subsection:

November 2010

102.12 Combination Bids. Combination bids for two or more projects may be required or permitted and may be designated as such in the bidding documents.

102.12.1 On required combinations, the bidder shall complete the bid for each project included in the combination.

102.12.2 On permitted combinations, the bidder will be allowed to combine all projects in the combination or bid each project separately. KTU reserves the right to determine the combination and make awards of the bids, that will be to the best interest of KTU, provided they are in conformance with the request for bids and the bids submitted.

102.12.2.1 When the bidder submits computer-generated itemized bid sheets for projects listed in permitted combination, the bidder shall include all itemized bid sheets for all projects. For conventional paper bids, the bidder shall indicate "No Bid" for all projects not bid. For electronic bids, the bidder shall leave the project's bid items blank for all projects not bid.

102.12.2.2 To combine all projects in a permitted combination, the bidder shall enter a complete bid for each project and mark the "All or None" box in the Request for Proposals. By marking "All or None" and combining all the projects, the bidder will be awarded all the projects in the combination or none of the projects.

102.12.2.3 If the bidder does not combine all of the projects, bids for the individual projects will be considered separately. The bidder shall complete the bid for each project the bidder desires to bid.

102.12.3 Two or more projects awarded in combination will be considered to be covered by a single contract. If during construction an item for which a unit price has not been bid is encountered in one project of a combination, the unit price bid for the same item in another project of the combination will apply, unless there is conclusive proof that conditions are changed significantly to effect a definite increase or decrease in the cost of the operation.

SECTION 201 – CLEARING AND GRUBBING

Replace the third sentence in Section 201.2.5.1 with the following text:

November 2010

The contractor shall obtain all necessary permits and approvals before open burning is initiated, and shall comply with permit conditions, MDNR regulations, and all laws in accordance with the General Requirements.

SECTION 202 - REMOVAL OF ROADWAYS AND BUILDING

After the last sentence of Paragraph 202.30.1.1, add the following text:

January 2010

All signs identified as removals will be removed by the Commission.

Replace Section 202.2.2 with the following text:

November 2010

202.2.2 Damaged Items. Any item damaged by the contractor's operations that is new material to be incorporated into the work or existing material designated to remain in place, to be used elsewhere or to be used by the public or an adjoining property owner, shall be repaired or replaced at the contractor's expense in a manner satisfactory to the engineer in accordance with the General Requirements.

SECTION 216 - REMOVALS FOR BRIDGE STRUCTURES

After the last sentence of Paragraph 216.10.1, add the following text:

January 2010

All painted steel contains lead paint. The contractor shall submit a demolition plan prior to start of bridge removal detailing means and methods for:

- (a) Protecting existing waterways
- (b) Abatement of lead based paint
- (c) Abatement of asbestos containing materials

SECTION 403 - ASPHALTIC CONCRETE PAVEMENT

After the last sentence of Paragraph 403.1, add the following text:

January 2010

At the contractor's option, if the project bridge is not on a major route and if the ADT is less than 2,000, cold mixed bituminous pavement mixture may be substituted for hot bituminous pavement mixture at bridge approaches.

SECTION 501 - CONCRETE

Delete the first sentence of Section 501.10.2 and replace it with the following text:

March 2011

501.10.2 Required Air Content. If air-entrained concrete is used, the designated quantity of air by volume shall be a minimum of 5.0 percent and a maximum of 8.0 percent.

SECTION 611 - EMBANKMENT PROTECTION

Delete Section 611.80.1 and replace it with the following text:

November 2010

611.80.1 Method of Measurement. Rock Blanket, Revetment, Concrete Slope Protection and Gabions will be measured to the nearest cubic yard of material complete in place.

Delete the first sentence in Section 611.80.2.1 and replace it with the following text:

November 2010

611.80.2.1 Embankment protection will be paid for at the Contract unit price for Section 611, Embankment Protection, for all work accepted and complete in place.

SECTION 616 - TEMPORARY TRAFFIC CONTROL

Add the following subsection:

January 2010

616.1.1 Requirements. The contractor shall develop, install, maintain and remove temporary traffic control for all:

- (a) Project Bridges on or over divided highways;
- (b) Project Bridges constructed with staged construction;
- (c) Project Bridges constructed using a bypass;
- (d) All roadways under a Project Bridge;
- (e) Work which is not continuous with the removal and replacement of a Project Bridge, such as core drilling and completion of punch list items; and
- (f) All warranty work.

The Commission shall be responsible for Maintenance of Traffic for all road closures for the removal and replacement of the remaining Project Bridges. The contractor will cooperate with Commission to ensure that all traffic control devices are protected and not disturbed. The contractor will coordinate access to the project bridge through the temporary traffic control with the engineer. The Commission will be responsible for all detour routes, with the reasonable cooperation of the contractor for

implementing any necessary adjustments to the operations to prevent disruption of the traffic flow resulting in unreasonable traffic delays.

When traffic control plans are the responsibility of the contractor, the contractor shall develop and submit, for Approval, Traffic Control Plans for each stage of construction on each Project Bridge that shows the contractor's proposed construction staging and proposed traffic control devices consistent with the MOT Plan. Revisions to a TCP shall also be submitted to the engineer for review and Approval. The TCPs shall include, at a minimum, a detailed diagram of the work zone that shows the location of all traffic control devices, lane widths, work zone speed limits, temporary bypasses and detour routing. The contractor shall provide Traffic Control Plans (TCP) and bypass detail sheets, if applicable, 120 Days prior to start of construction for each Project Bridge that the Contractor is responsible for developing TCP. Any contractor provided MOT Plan shall identify the contractor's strategy to provide for the safe and efficient movement of people, goods and services through and around each Project Bridge while minimizing impacts to local residents, business and commuters; such MOT Plan shall include:

- (a) Traffic Control Plans (TCP);
- (b) Plan to maintain resident, business and school access to emergency and other service providers;
- (c) Plan to minimize traffic impacts to school districts, businesses, farmers and local residents;
- (d) Plan to maintain and control pedestrian, bicycle and other non-vehicular traffic.
- (e) Public information plan to share information about the Project Bridge, including but not limited to construction schedule and potential traffic impacts, with those potentially affected.

Access to all parcels within each improvement limit shall be maintained or the contractor shall provide alternative access. Contractor shall describe the MOT Plan with reasonable, measurable tasks and milestones. The contractor shall conform to the following:

- (a) The contractor shall notify the engineer of any lane and road closures necessary to perform work on each Project Bridge by submitting a Notice of Intent to Perform Work form prior to instituting or changing such traffic control measures. This form shall be submitted at least 2 Business Days prior to start of construction or impact to traffic and should include the state bridge number, date and time of day, which must be within regular business hours, the Project Bridge closure is being requested. The Notice of Intent to Perform Work form is located at <http://www.modot.org/asp/intentToWork.shtml>.
- (b) The contractor shall notify the engineer 17 Business Days prior to any vertical clearance reduction that provides less than 18 foot clearance, any load capacity reductions or any width reduction that results in a restriction of less than 20 feet, which includes road closures. Notification shall be in the form of the Overdimension/Overweight Workzone Restriction Request Form.
- (c) Any Project Bridge that is or has an overhead obstruction shall have a MoDOT's motor carrier services Bridge Clearance Report completed and submitted to the engineer before the over-dimension/overweight work zone restriction is removed. This submittal should be prior to the bridge opening and as close as reasonably practical.
- (d) The contractor's placement of construction equipment, materials and vehicles shall comply with AASHTO policies and guidelines.

The contractor shall be responsible for maintaining the existing traffic flow through the job site. If disruption of the traffic flow occurs with unreasonable traffic delays, the contractor shall review the construction operations that directly contributed to the disruption of the traffic flow and make any limited adjustments to the operations to reduce or prevent the queues from reoccurring. Limited adjustments to stage or bypass traffic control would include such actions as pothole patching in the travel lane(s), adjustment of traffic tapers or other temporary and moveable traffic control devices, or movement/addition of advance signing.

SECTION 617 - CONCRETE TRAFFIC BARRIER

Delete Sections 617.40.2.1 and 617.40.2.2 in their entirety and replace them with the following:

March 2010

617.40.2.1 Permanent Concrete Traffic Barrier. Work required and performed under Section 616.10, Permanent Concrete Traffic Barrier, and Section 617.30, Traffic Barrier Delineators, will be considered incidental to Section 703, Class B-1 Concrete (Superstructure). No additional payment will be made for work under this Section.

617.40.2.2 Temporary Traffic Barrier and Delineators. Work required and performed under Section 617.20, Temporary Traffic Barriers, will be considered incidental to Section 616, Temporary Traffic Control. No additional payment will be made for work under this Section.

SECTION 620 - PAVEMENT MARKING

After the last sentence of Paragraph 620.1, add the following text: **January 2010**

The contractor shall provide all temporary pavement markings. If pavement markings are to be relocated during construction, temporary marking shall be provided. Conflicting pavement markings, either temporary or permanent, shall be removed. Permanent pavement marking will be installed by the Commission upon completion of the Project Bridge. The contractor will be responsible all temporary and permanent pavement markings on Project Bridges that are not closed.

SECTION 627 - CONTRACTOR SURVEYING AND STAKING

After the last sentence of Paragraph 627.2.1 add the following text: **January 2010**

The engineer will provide two control points at each project bridge.

SECTION 701 - DRILLED SHAFTS

Delete the following sentence from Paragraphs 701.6.1, 701.6.2 and 701.6.3: **March 2010**

Reinforcing steel will not be measured or paid for separately and will be considered incidental to Section 706, Reinforcing Steel (Plain) or Section 710, Reinforcing Steel (Epoxy Coated), whichever applies.

Replace the last sentence of Paragraph 701.7.1 with the following text: **March 2010**

Reinforcing steel required under this Section will be considered incidental to the payment for Drilled Shafts.

Replace the last sentence of Paragraph, 701.7.2 with the following text: **March 2010**

Reinforcing steel required under this Section will be considered incidental to the payment for Rock Sockets.

Replace the last sentence of Paragraph 701.7.3 with the following text: **March 2010**

Reinforcing steel required under this Section will be considered incidental to the payment for Technique Shafts.

SECTION 702 - LOAD BEARING PILES

Delete the Design Bearing Formula tables in Section 702.4.10 and replace them with the following: **June 2010**

| |
|--|
| ENGLISH |
| $P = 1.75(E)^{0.5} \log_{10}(10N) - 100$ |
| METRIC |
| $P = 7(E)^{0.5} \log_{10}(10N) - 550$ |

Delete the Pile Batter Factor formula in Section 702.4.10.2 and replace it with the following: **June 2010**

$$B = \frac{0.1 (10 - m)}{(1 + m^2)}, \text{ pile batter factor}$$

Add the following subsection:

January 2010

702.2.7 Owner/Contractor Furnishing Piling. All piling for use in the work shall be furnished by KTU Constructors. Piling will be furnished in standard lengths of between forty (40) and sixty (60) feet. The contractor shall provide the engineer a Pile Order Request indicating the number of each length requested and the requested delivery date for a project bridge within five (5) days of receiving Notice to Proceed 1 (NTP1).

Delete Paragraph 702.5.2 in its entirety and replace it with the following:

May 2010

702.5.2 Load-Bearing Piles.

702.5.2.1 H-Pile. H-Piles in place will be the actual length of all H-piles, except test piles, measured to the nearest foot (0.5 m) for that portion of each pile that remains permanently in the structure.

702.5.2.1 Pipe Pile. Pipe Piles in place will be the actual length of all pipe piles, except test piles, measured to the nearest foot (0.5 m) for that portion of each pile that remains permanently in the structure.

~~*After the last sentence of Paragraph 702.6.2, add the following text:*~~

~~*March 2010*~~

~~All concrete and rebar for pipe pile will be considered incidental to Section 702, Load Bearing Piles, and will not be paid for separately.~~

Delete Paragraph 702.6.2 in its entirety and replace it with the following:

May 2010

702.6.2 Load-Bearing Piles.

702.6.1 H-Pile. Load Bearing Piles (H-Pile) will be paid for at the Contract unit price for all work accepted and complete in place. No direct payment will be made for incidental items necessary to complete the work unless specifically provided as a pay item in the contract.

702.6.2 Pipe-Pile. Load Bearing Piles (Pipe Pile) will be paid for at the Contract unit price for all work accepted and complete in place. No direct payment will be made for incidental items necessary to complete the work unless specifically provided as a pay item in the contract.

702.6.3. All concrete and rebar for pipe pile will be considered incidental to Section 702, Load Bearing Piles, and will not be paid for separately.

SECTION 704 - CONCRETE MASONRY REPAIR

Replace the eighth sentence in Section 704.4.1.4 with the following text:

November 2010

Environmental protection shall be in accordance with the General Requirements.

SECTION 711 - PROTECTIVE COATINGS

Add the following subsections:

April 2010

Section 711.3.6 Protective Coatings for Exposed Concrete Beams.

Protective coating is required for the exterior concrete girders shall be from the following list of manufacturers. Protective coating shall be required from the uppermost exterior edge extending down and underneath to the innermost edge of the exterior box beam or cored slab on both sides of the bridge for its entire length. Girders may be supplied by KTU with the protective coating already applied, otherwise the subcontractor will be required to apply the protective coating at the project bridge site.

This protective coating shall consist of a two-component, modified polyamide converted epoxy, in a color as directed by the engineer. New concrete shall cure a minimum of 10 days prior to application of the protective coating. The coating shall be applied to dry surfaces. The surface preparation and application shall be in accordance with the manufacturer's recommendations. The coating shall be applied to obtain a minimum dry film thickness of 6 mils (150 µm). The following products may be used for protective coating on exposed concrete beams:

| Brand Name | Manufacturer |
|-------------------------|--|
| Macropoxy 646 Fast Cure | The Sherwin-Williams Company 10440 E. Northwest Highway Dallas, TX 75238 |

If required by the engineer, Field-Application of Epoxy Coating will be paid for at the contract lump sum price for all work required and performed under this provision.

Section 711.3.7 Protective Coatings for Formed Deck Drains.

Protective coating shall be applied to all interior surfaces of formed deck drains shown on bridges with asphalt overlays. This protective coating shall also be applied to the horizontal surface of the exterior box beam or cored slab adjacent to approach side of each deck drain for a distance of twelve inches from the face of the barrier curb. The protective coating shall extend six inches upstream along the flowline from the upstream edge of the drain, and six inches downstream along the flowline from the downstream edge of the drain.

This protective coating shall consist of a two-component, modified polyamide converted epoxy, in a color as directed by the engineer. New concrete shall cure a minimum of 7 days prior to application of the protective coating. For concrete that has cured for less than 28 days, one coat of Primer will be required prior to application of the top coat. Cure time for primer shall be in accordance with the manufacturer's recommendations. For concrete that has cured for 28 days or more, only one top coat will be required (no primer). The coating shall be applied to dry surfaces. The surface preparation and application shall be in accordance with the manufacturer's recommendations. The primer shall be applied to obtain a minimum dry film thickness of 5 mils. The top coating shall be applied to obtain a minimum dry film thickness of 6 mils.

No measurement for payment will be made for this work and the payment will be considered incidental to the Pay Item 703 Class B-1 Concrete (Superstructure).

The following products (or equivalent with prior approval of the engineer) may be used for protective coatings for formed deck drains:

| Brand Name | Manufacturer |
|---------------------------|---|
| Carboguard 635 (Primer) | Carboline Co. 350 Hanley Industrial Ct. St. Louis, MO 63144 |
| Carbomastic 94 (Top Coat) | Carboline Co. 350 Hanley Industrial Ct. St. Louis, MO 63144 |

SECTION 903 - HIGHWAY SIGNING

After the last sentence of Paragraph 903.1, add the following text:

January 2010

The Commission will install new signing as required, except for any signs that are damaged or unnecessarily removed by the contractor and delineation at bridge ends.